

# S SERIES<sup>®</sup>

★YODER SMOKERS★

## SHORT THERMOCOUPLE CONVERSION

YS640 / YS480 INSTALLATION INSTRUCTIONS

---

### BEFORE YOU GET STARTED

**DO NOT INSTALL** until you have completed Step 23 of the ACS Retrofit. Begin by confirming all the parts included in this kit are accounted for. The diagram below shows each item in this kit. *Should any items be missing, please contact Customer Service for assistance at 877.409.6337 or customerservice@yodersmokers.com.*

#### PARTS INCLUDED

- (1) Short Thermocouple
- (1) Thermocouple Wire Cover
- (3) Self-Drilling Screws (1 spare)
- (1) 5/32" Drill Bit

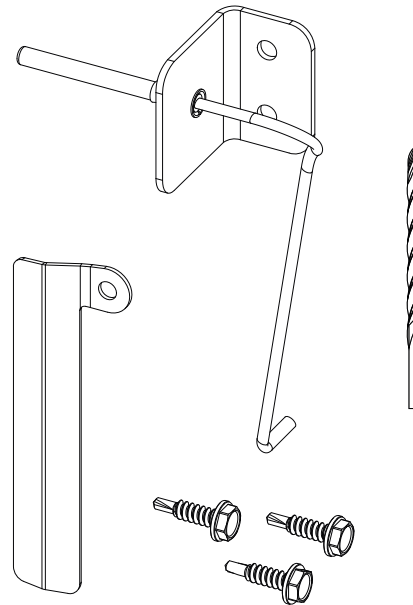

---

### TOOLS YOU'LL NEED

5/16" Socket | Drill | Phillips Head Screwdriver



**CAUTION:** BEFORE BEGINNING THIS PROCEDURE, ENSURE THAT THE POWER CORD TO THE SMOKER IS DISCONNECTED! FAILING TO DO SO MAY RESULT IN BODILY INJURY.  
**COMPETITION CART MODELS REQUIRE UNPLUGGING THE POWER CORD FROM THE HOPPER LOCATED UNDER THE CART.**

## STEP 1

Using the Phillips head screwdriver and 5/16" socket, remove the two screws and nuts securing the long thermocouple bracket to the back wall and remove the thermocouple from the chamber.

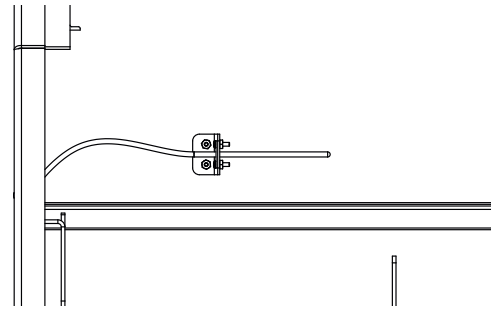

## STEP 2

Use the two screws removed from the previous step and secure them into the same holes

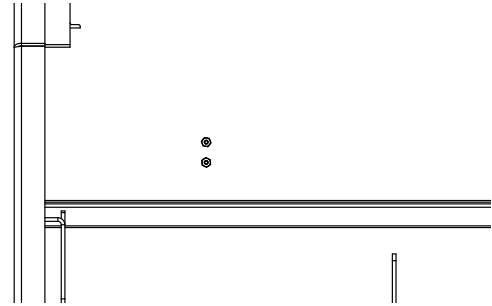

## STEP 3

Using the template provided in these instructions, cut along the dotted lines and position the template as shown. Drill the holes through the template using the 5/32" drill bit provided.

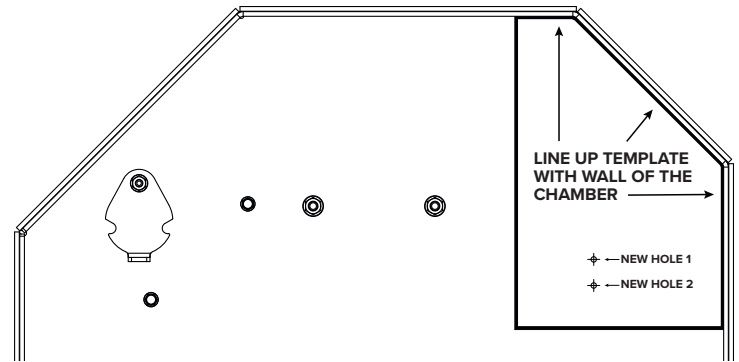

## STEP 4

Align the new short thermocouple bracket with the holes and using the 5/16" socket, secure the bracket to the wall of the cooker with the two self-drilling screws. Feed the thermocouple wire into the hopper through the hole in the chamber.

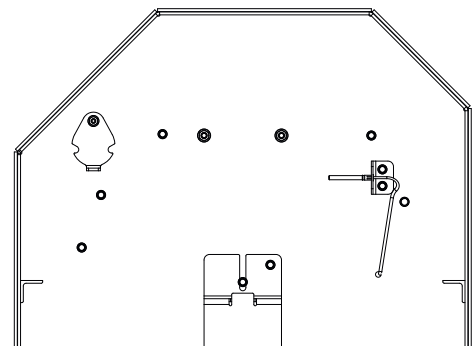

## STEP 5

Remove the self-drilling screw (as shown) and place the thermocouple wire cover over the steel braided wire. Secure the bracket with the self-drilling screw. Continue on to Step 24 of the ACS Retrofit install.

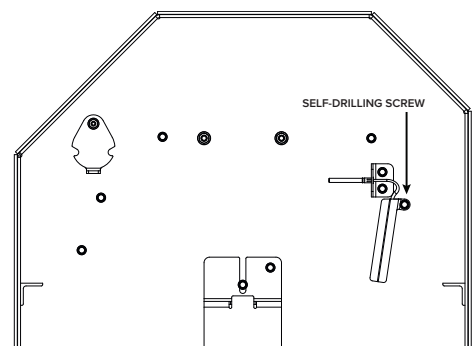



# THERMOCOUPLE BRACKET TEMPLATE



**CUT ALONG DASHED LINES**

LINE UP EDGES WITH CHAMBER

LINE UP THIS EDGE WITH THE BACK  
WALL OF THE CHAMBER

THIS EDGE **NOT** FOR LOCATION

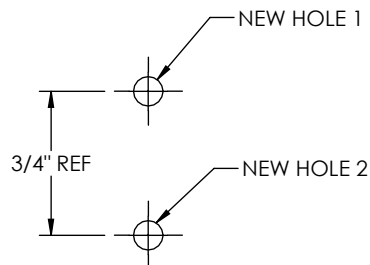

THIS EDGE **NOT** FOR LOCATION