

ITEM	PART #	DESCRIPTION	REV	QTY
1	A45745	YS, ASSEMBLY, CHARCOAL GRILL, 24x48, TRAILER MOUNTED	E	1
2	A47960	YS, ASSEMBLY, 2" GREASE DRAIN, 8" MID PIPE	-	1
3	W41523	YS, WELDMENT, DAMPER HANDLE, FIREBOX	B	1
4	W44837	YS, WELDMENT, FIRE GRATE, 24" SQ FB w/ LL	-	2
5	W46232	YS, CIMARRON, 26x66, COOKING GRATE WELDMENT	A	3
6	W48110	YS, CHARCOAL GRILL, SHORT TRAY HANDLE WELDMENT, LEFT	-	1
7	W48132	YS, WELDMENT, SQ FB DOOR, CIMARRON & CHISHOLM, SPRING HANDLE	C	1
8	W48210	YS, WELDMENT, CHARCOAL BASKET, KINGMAN, CIMARRON, & 24" STOCKTON	-	1
9	W48930	YS, WELDMENT, REMOVABLE HMP SECTION 1, CIMARRON 26x54 & 66	-	1
10	W48934	YS, WELDMENT, REMOVABLE HMP SECTION 3, CIMARRON 26x66	-	1
11	W48940	YS, WELDMENT, SMOKER, CIMARRON II w/ SQ INS FB	-	1
12	W48942	YS, WELDMENT, TRAILER BODY, CIMARRON w/ CHARCOAL	-	1
13	W48970	YS, TONGUE BOX LID WELDMENT, CIMARRON TRAILER w/CHARCOAL	-	1
14	W48972	YS, 2nd SHELF WELDMENT, CIMARRON 26x66	A	2
15	W49020	YS, WELDMENT, CHARCOAL GRILL MOUNT LEG	-	2
16	22860	YS, TAG, SERIAL NUMBER	-	1
17	22866	YS, HANDLE, SPRING, 5.75" LONG, 1/2" HOLE	-	7
18	22924	PUSH CAP, NICKEL PLATED, 3/8", 94803A031	-	6
19	23108	PUSH CAP, NICKEL PLATED, 1/2", 94803A050	-	3
20	23721	TRAILER, JACK, CASTER WHEEL FOR 23720	-	1
21	23994	TRAILER, LUG NUT, 1/2"-20, BLACK, TW-1954BK	-	12
22	24086	GAS SPRING, 15.24" EXT, 9.76" COMP, 60#, C16-24189 / 4138T556	-	3
23	24142	TRAILER, SAFETY CHAIN PAIR, CLASS II, 3500#	-	1
24	24164	COTTER, HAIRPIN, 9/64 DIA. X 3.38 LONG FOR 3/4 TO 1-1/8	-	1
25	24171	YS, TEMP GAUGE, 3", TEL-TRU UT300, 3" STEM, CUSTOM DIAL	-	4
26	24197	NUT, JAM, 1/2" NPT, NICKEL PLATED BRASS	-	4
27	24237	LATCH, SIDE BOLT, FLUSH, PUSH TO CLOSE, BLACK, W/KEYS	-	1
28	24254	TRAILER, CONNECTOR ASSY, 8FT, 7-STRAND, 7-POLE RV	-	1
29	24255	TRAILER, BOX, JUNCTION, W/HARDWARE, 7 STUD, J-JB-4	-	1
30	24256	CONNECTOR, WIRE, #10 RING, 12-10 GA, W/SHRINK	-	1 PKG
31	24257	CONNECTOR, WIRE, #10 RING, 16-14 GA, W/SHRINK	-	1 PKG
32	24258	CONNECTOR, WIRE, BUTT, 14-16 AWG, MULTI, W/SHRINK	-	1 PKG
33	24340	EDGE TRIM, 1/8" GRIP, 7/16" TOP BULB, FOAM RUBBER	-	1
34	24502	LED LICENSE PLATE LIGHT, TOP MOUNT, PETERSON 290C	-	1
35	24563	CLEVIS PIN 1" x 2-1/2" LOW CARBON STEEL, PAINTED	-	1
36	41302	YS, LATCH PIN, DOUBLE DOOR	-	1
37	41435	YS, ROD HANDLE, 3/8" x 7.75" LONG, ZINC	-	2
38	41597	YS, TRAILER, GRILL MOUNT TAB	-	6
39	44047	YS, SIGN, COMP CART, COUNTERWEIGHT, 7x16	A	2
40	46294	YS, CIMARRON TRAILER, 26x66, STAINLESS SHELF, FRONT ENDCAP	A	2
41	46295	YS, CIMARRON TRAILER, 26x66, STAINLESS SHELF, REAR ENDCAP	A	2
42	46464	YS, LIGHT, SIT, OVAL, LED, SURFACE MOUNT, 4" x 2 1/2"	-	2
43	46569	PIPE, NIPPLE, 2" x 4 1/2", BLK, SCH 40	-	1
44	46696	TRAILER, WHEEL, CENTER CAP, BLACK, 3.75", TW-S1050-385BB	-	2
45	46700	YS, LIGHT, 15" IDENTIFICATION BAR, RED LED	-	1
46	46703	YS, GASKET, OPTRONICS MCL70 SERIES LAMP	-	1
47	46807	YS, STAINLESS FRONT SHELF, CIMARRON TRAILER w/640	A	2
48	46892	YS, SHOVEL, FIREPLACE, 30"	-	1
49	47083	TRAILER, WHEEL, ALUMINUM, BLACK, 16 x 6", 6 ON 5 1/2"	-	2
50	47156	YS, BLOCK-OFF PLATE, LOG LIGHTER	B	1
51	47157	TIRE, 205/70R16, 1609# CAP	-	2
52	47388	YS, PLATE, SLIDE DAMPER, CIMARRON	B	1
53	47797	YS, STRIKER TAB, TONGUE BOX	-	1
54	48312	YS, LAMP, CLEARANCE, 3-1/4" DIAMOND, AMBER LED, PC	-	2
55	48313	YS, LAMP, CLEARANCE, 3-1/4" DIAMOND, RED LED, PC	-	2
56	48314	YS, LAMP, CLEARANCE, BEZEL ONLY, BLACK, FOR 48312 & 48313	-	4
57	48327	YS, BRACKET, LICENSE PLATE MOUNT EXTENSION, US	A	1
58	48974	YS, SIGN, CERTIFIED PIEDMONTESE	-	2
59	90377	THUMBSCREW, 5/16-18 X 3/4	-	1
60	90460	BUCKET, GALVANIZED, 15.2 x 11 x 12.7cm, WITH YS LOGO	-	1
61	91420	Plug, Panel, 1.125" Hole, 1.5" Dia, Plastic, Black	-	2
62	91687	YS, BANNER SIGN, 26" CIMARRON PELLET	-	1
63	91415	YS, HINGE, DOOR, 3" x 1 1/2", 5-HOLE, SS, VERT. PELLET SMOKER	-	4

ITEM	PART #	DESCRIPTION	REV	QTY
64	14FW	WASHER, FLAT, 1/4"	-	2
65	1024FHN	NUT, HEX, FLANGE, 10-24, GR5, ZN	-	16
66	1024HN	NUT, HEX, 10-24, GR2, ZN	-	4
67	1024X2PHMSP	SCREW, MACHINE, PAN HEAD, PHILLIPS, 10-24 x 2"	-	2
68	1024X12PHMSP	1024X12PHMSP	-	4
69	1024X34PHMSP	SCREW, MACHINE, PAN HEAD, PHILLIPS, 10-24 x 3/4"	-	2
70	1024X58PHMSS	SCREW, MACHINE, FLAT HEAD, PHILLIPS, 10-24 x 5/8, STAINLESS	-	30
71	1032X34PHMSP	SCREW, MACHINE, PAN HEAD, PHILLIPS, 10-32 x 3/4"	-	4
72	1213FHN	NUT, HEX, FLANGE, 1/2-13, GR5, ZN	-	6
73	1213HJN	NUT, HEX, JAM, 1/2-13, GR5, ZN	-	1
74	1213X112BHCSS	SCREW, CAP, BUTTON HEAD, 1/2-13 x 1 1/2", STAINLESS	-	6
75	1213X114HB	BOLT, HEX, 1/2-13 x 1 1/4", GR5, ZN	-	4
76	1420FHN	NUT, HEX, FLANGE, 1/4-20, GR5, ZN	-	18
77	1420X1FHB	BOLT, HEX, FLANGE, 1/4-20 x 1, GR5, ZN	-	2
78	1420X34HB	BOLT, HEX, 1/4-20 x 3/4", GR5, ZN	-	2
79	1420X58BHCSS	SCREW, CAP, BUTTON HEAD, 1/4-20 x 5/8", STAINLESS	-	40
80	236-2489-02	RIVET, POP, 1/8 DIA. X 3/8 GRIP	-	4
81	236-6374-02	WASHER, LOCK, EXTERNAL TOOTH, #10	-	8
82	5811HN	NUT, HEX, 5/8-11, GR5, ZN	-	2
83	51618HN	NUT, HEX, 5/16-18, GR5, ZN	-	6
84	8LWE	WASHER, LOCK, EXTERNAL TOOTH, #8	-	8
85	832HN	NUT, HEX, 8-32, GR2, ZN	-	8
86	832X34PHMSP	SCREW, MACHINE, PAN HEAD, PHILLIPS, 8-32 x 3/4"	-	8
87	701-212-02	COTTER, HAIRPIN, 1/8 DIA X 2-3/8, 1/2 TO 5/8 PIN	-	1

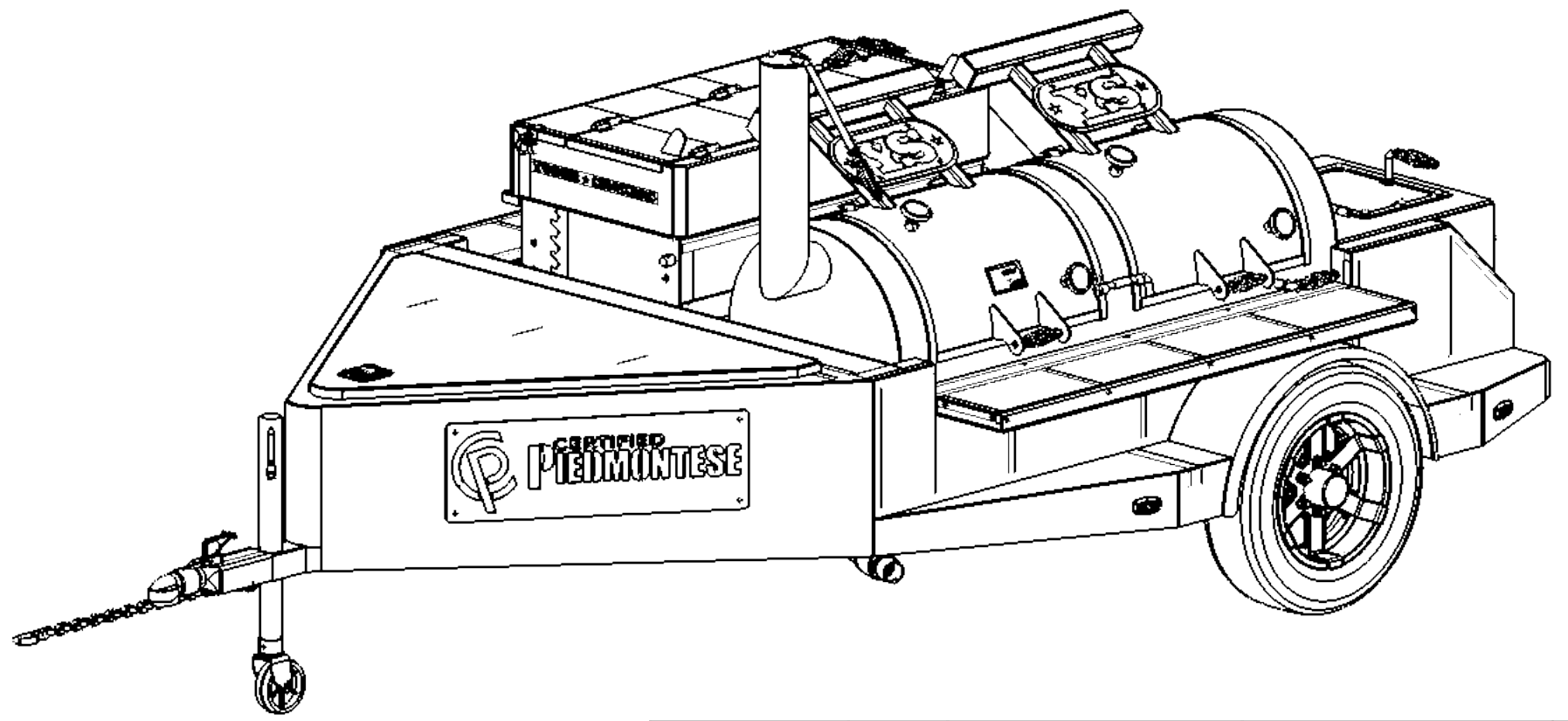

	SHEET SIZE <b>B</b>	DO NOT SCALE DRAWING	MATL # --	REV -
	1 PAGE OF 2	MATERIAL SPEC. SEE BOM		
UNLESS OTHERWISE SPEC.	DESCRIPTION YS, ASM, SKIRTED TRAILER, CIMARRON 26x66, w/24x48 CHARCOAL			
<small>DIMNS. IN INCHES ANSI Y14.5 - 1994 STD. TOLERANCES X.X ± .060 X.XX ± .030 X.XXX ± .010 FRAC.DIM. ± 1/32 DEG. ± 1 BREAK ALL EDGES 010 - 015</small>	DRAWING NUMBER <b>A48908</b>			
	DRAWN BY JE	DATE 11/8/18	<small>NOTICE: THIS DOCUMENT AND ITS CONTENTS ARE THE PROPERTY OF YODER SMOKERS, INC. NO USE OR COPIES MAY BE MADE WITHOUT WRITTEN PERMISSION.</small>	

REVISIONS				
ECN	REV.	DESCRIPTION	DATE	APPROVED

NOTE: TRAILER WEIGHT APPROX: 3900 lbs

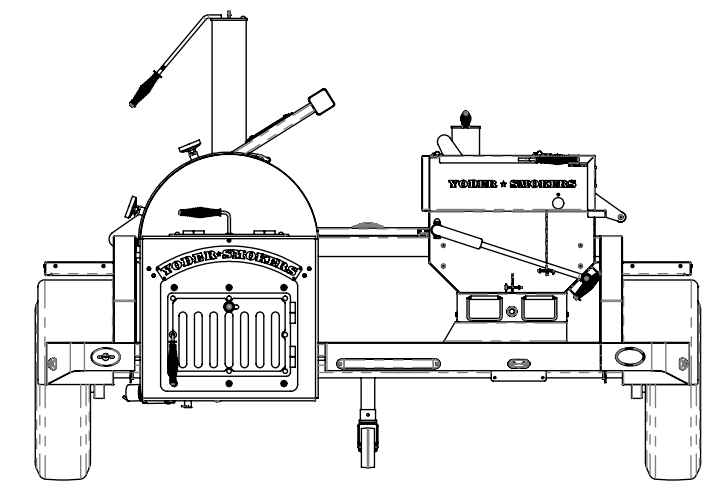
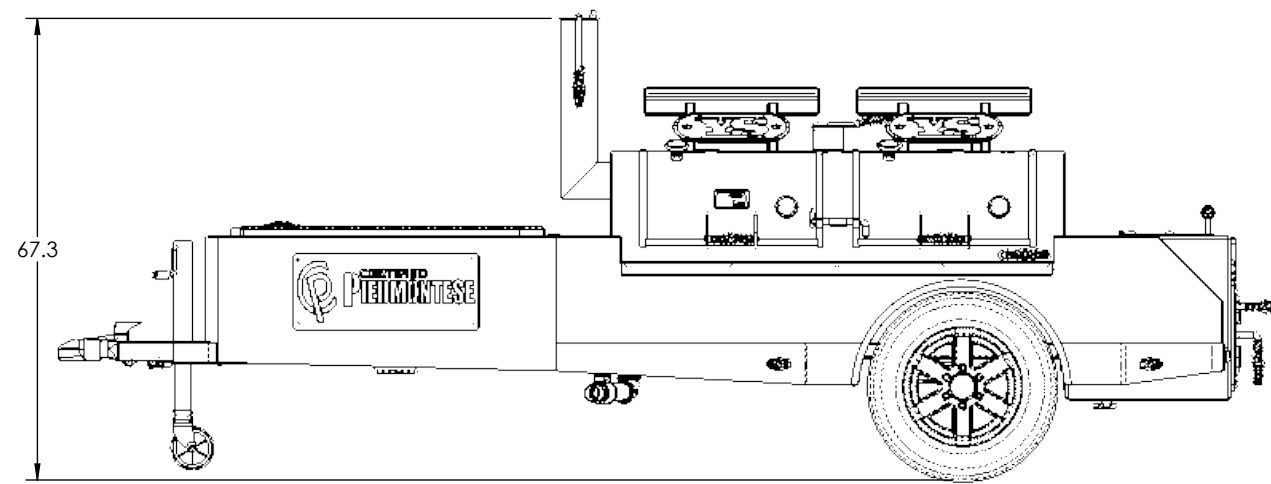
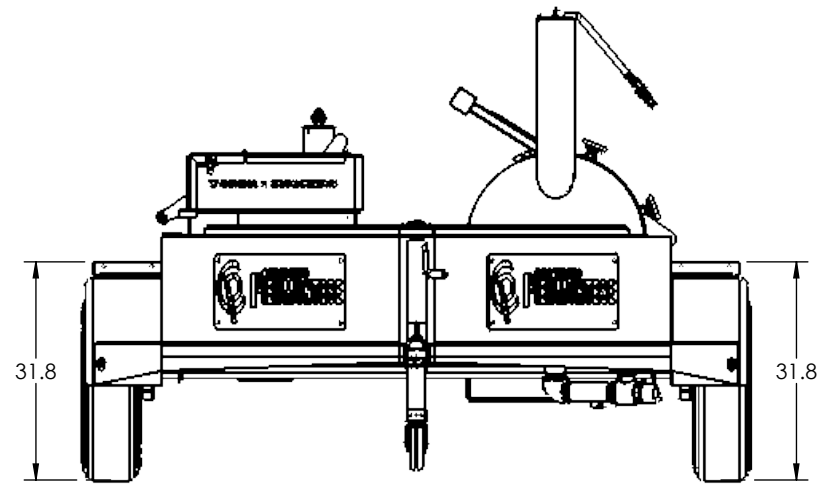
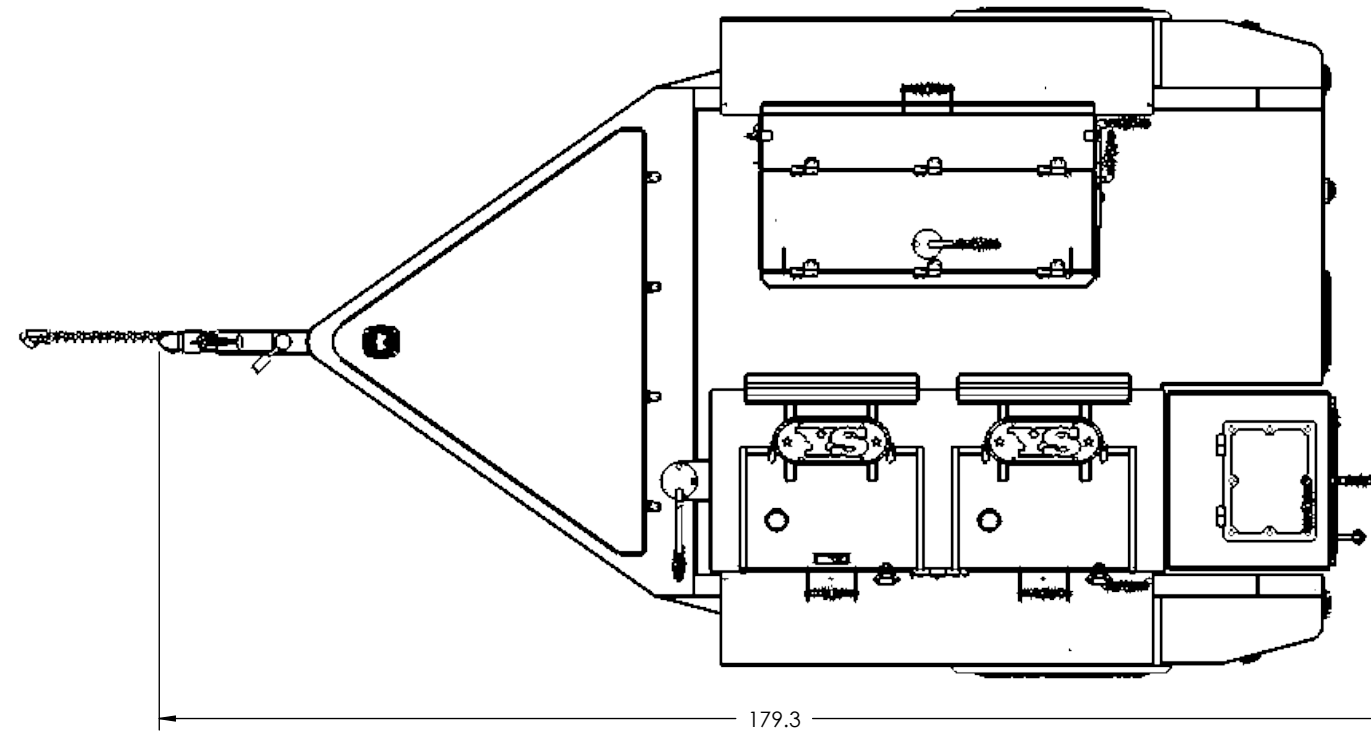

	SHEET SIZE <b>B</b>	DO NOT SCALE DRAWING	MATL # --	REV -
	3RD ANGLE PROJECTION	2 OF 2	MATERIAL SPEC. SEE BOM	
UNLESS OTHERWISE SPEC.	DESCRIPTION YS, ASM, SKIRTED TRAILER, CIMARRON 26x66, w/24x48 CHARCOAL			
DIMNS. IN INCHES ANSI Y14.5 - 1994 STD. TOLERANCES X.X ± .060 X.XX ± .030 X.XXX ± .010 FRAC.DIM. ± 1/32 DEG. ± 1 BREAK ALL EDGES 010 - 015	DRAWING NUMBER <b>A48908</b>			
	DRAWN BY JE	DATE 11/8/18	NOTICE: THIS DOCUMENT AND ITS CONTENTS ARE THE PROPERTY OF YODER SMOKERS, INC. NO USE OR COPIES MAY BE MADE WITHOUT WRITTEN PERMISSION.	

A48908