

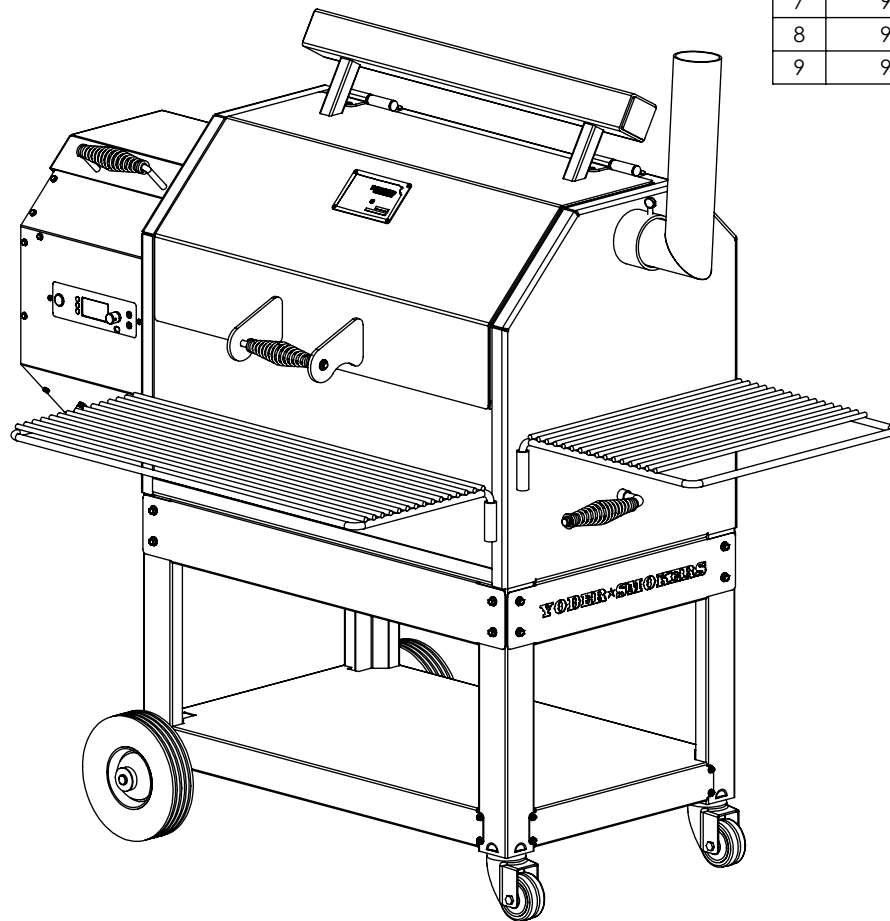

9611X11-000





ITEM	PART #	DESCRIPTION	REV	QTY
1	W91641	YS, WELDMENT, HEAT DIFFUSER PLATE w/RIB, 640 PELLE	-	1
2	W90067	YS, WELDMENT, CHIMNEY, PELLE	B	1
3	A92475	YS, ASSY, NEW, CHAMBER HOPPER, 640, PELLE, 120V, (LH)	--	1
4	A91845	YS, BOX ASSEMBLY, COOKING GRATES/MANUAL, YS640	-	1
5	A91841	YS, BOX ASSEMBLY, BUCKET/ HARDWARE/ PAINT	B	1
6	A90490	YS, ASSEMBLY, CART FRAME, 640 PELLE	L	1
7	91830	YS, POUCH, FOAM, 1/8", CHIMNEY	-	1
8	90896	YS, END SHELF, CHROME, 480/640 PELLE	A	1
9	90895	YS, FRONT SHELF, CHROME, 640 PELLE	A	1

 3RD ANGLE PROJECTION	SHEET SIZE A	DO NOT SCALE DRAWING	MATL # --	REV
	1 PAGE OF 2	MATL SPECS SEE BOM		
UNLESS OTHERWISE SPEC.	DESCRIPTION	S,640,STAND,WIRE		
DIMS IN INCHES ANSI Y14.5 - 1994 STD. TOLERANCES X.X ± .060 X.XX ± .030 X.XXX ± .010 FRAC.DIM. ± 1/32 DEG. ± 1 BREAK SHARP EDGES .010 - .015	DRAWING NUMBER	 9611X11-000		
REVISIONS	DRAWN BY GT	DATE 04/17/19		
ECN	REV.	DESCRIPTION	DATE	APPROVED

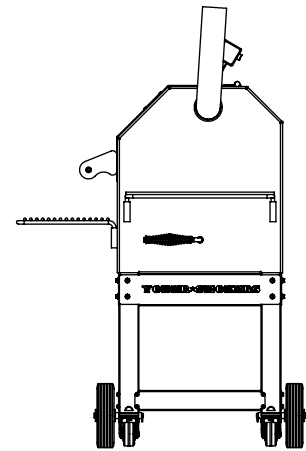
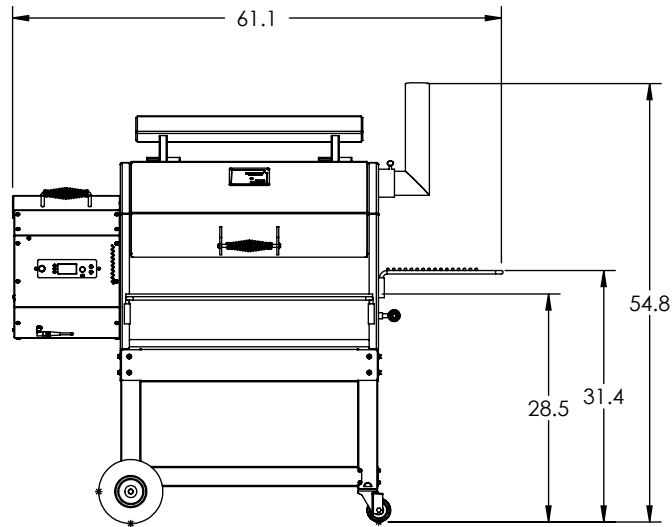
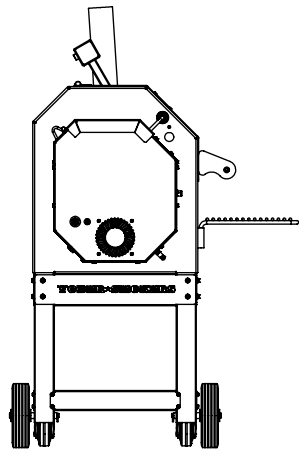
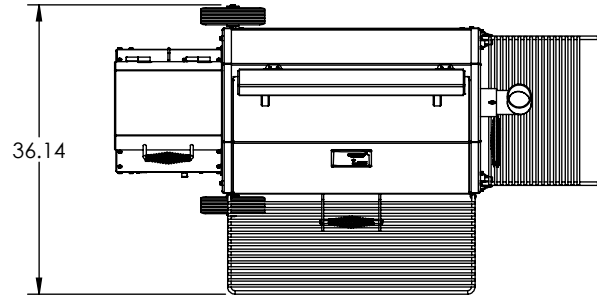
NOTICE: THIS DOCUMENT AND ITS CONTENTS ARE THE PROPERTY OF YODER SMOKERS, INC. NO USE OR COPIES MAY BE MADE WITHOUT WRITTEN PERMISSION.

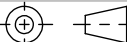

 3RD ANGLE PROJECTION	SHEET SIZE A	DO NOT SCALE DRAWING	MATL # --	REV
	2 PAGE OF 2	MATL SPECS SEE BOM		
UNLESS OTHERWISE SPEC.	DESCRIPTION S,640,STAND,WIRE			
DIMS IN INCHES ANSI Y14.5 - 1994 STD. TOLERANCES X, X ± .060 X, XX ± .030 X, XXX ± .010 FRAC.DIM. ± 1/32 DEG. ± 1 BREAK SHARP EDGES .010 - .015	DRAWING NUMBER 9611X11-000		 NOTICE: THIS DOCUMENT AND ITS CONTENTS ARE THE PROPERTY OF YODER SMOKERS, INC. NO USE OR COPIES MAY BE MADE WITHOUT WRITTEN PERMISSION.	
	DRAWN BY GT	DATE 04/17/19		